

MPTA-C2c-2002
Reaffirmed 2010

Elastomeric Coupling Alignment

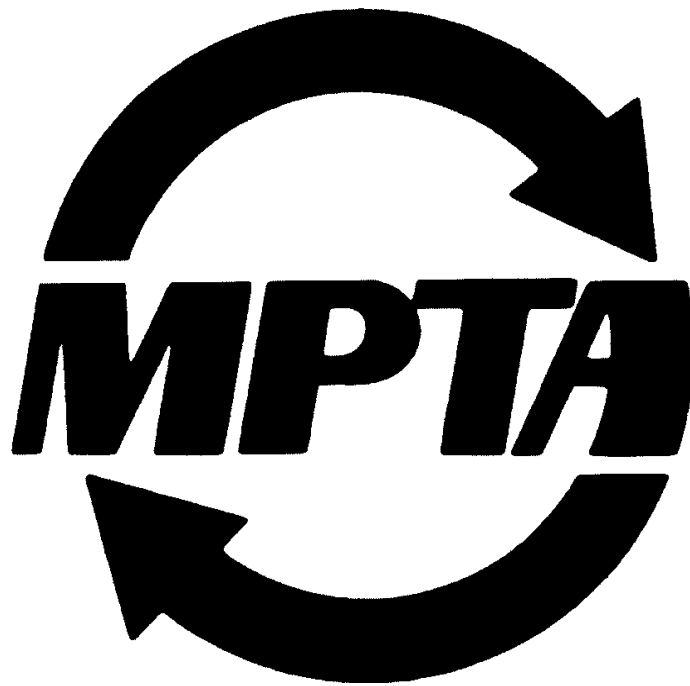

MPTA Primer

Mechanical Power Transmission Association
6724 Lone Oak Blvd., Naples, FL 34109
www.mpta.org

Contributors

Baldor, Dodge Reliance & Maska	Greenville SC	www.baldor.com
Baldor, Maska Canada	Ste. Claire Quebec, Canada	www.maskapulleys.com
Emerson Power Transmission	Maysville, KY	www.emerson-ept.com
Frontline Industries, Inc	Irvington, Ny	www.frontlineindustries.com
Lovejoy, Inc.	Downers Grove, IL	www.lovejoy-inc.com
Magnaloy Coupling Company	Alpena, MI	www.magnaloy.com
Martin Sprocket & Gear, Inc.	Arlington, TX	www.martinsprocket.com
Maurey Manufacturing Corp.	Holly Springs, MS	www.maurey.com
Rexnord Industries, LLC	New Berlin, WI	www.rexnord.com
TB Wood's Incorporated	Chambersburg, PA	www.tbwoods.com

Disclaimer Statement

This publication is presented for the purpose of providing reference information only. You should not rely solely on the information contained herein. Mechanical Power Transmission Association (MPTA) recommends that you consult with appropriate engineers and / or other professionals for specific needs. Again, this publication is for reference information only and in no event will MPTA be liable for direct, indirect, incidental or consequential damages arising from the use of this information.

Abstract

This primer is intended for individuals who need to understand the necessity for shaft alignment with elastomeric couplings, types of alignment, factors that affect alignment, and the basic practices to achieve acceptable alignment of the connected equipment

Copyright Position Statement

MPTA publications are not copyrighted to encourage their use throughout industry. It is requested that the MPTA be given recognition when any of this material is copied for any use.

Table of Contents

Foreword		Page 5
Scope		Page 5
Section 1	Common Terms and Definitions	Page 6
Section 2	Overview of Alignment	Page 7
	2.1 Importance of Alignment	Page 7
	2.2 Pre-Alignment Considerations	Page 9
Section 3	Types of Shaft Misalignment	Page 10
	3.1 Angular Misalignment	Page 10
	Figure 1	Page 11
	3.2 Parallel Offset Misalignment	Page 12
	Figure 2	Page 13
Section 4	Comparison of Alignment Methods	Page 14
	4.1 Straight Edge Method	Page 14
	Figure 3	Page 14
	4.2 Rim and Face method	Page 15
	Figure 4	Page 15
	4.3 Reverse Indicator Method	Page 16
	Figure 5	Page 16
	4.3 Laser Alignment	Page 17
Appendix A	Determination of Indicator Sag	Page 18
	Figure 6	Page 18
	Cautions on Runout	Page 19

Foreword

This foreword contains reference information and is not to be construed to be part of any technical specification.

This primer is intended for individuals who need to understand the necessity for shaft alignment with elastomeric couplings, types of alignment, factors that affect alignment, and the basic practices to achieve acceptable alignment of the connected equipment. The reason shaft alignment is critical is that it reduces the reactionary forces put upon the equipment by the coupling and other connections. This reduction in forces leads to longer equipment, bearing, shaft, coupling, and seal life which results in reduced operating costs for the equipment users.

Suggestions for the improvement, or comments on this publication are welcome. Comments should be mailed on company letter head to Mechanical Power Transmission Association, 6724 Lone Oak Blvd., Naples, Fl

Scope

This primer covers equipment alignment for elastomeric couplings.

Section 1 – Common Terms to Know

Flexible Coupling -

A mechanical fastening device used to connect two rotating shafts for power transmission that accommodates equipment misalignment.

Elastomer

Resilient material having elastic properties. (rubber, synthetic rubber or plastics)

Elastomeric Element

An assembly of components designed to connect axially oriented shafts in order to provide power transmission and accommodate shaft misalignment through elastomeric materials

Angular Alignment

A measure of the angle between two shafts

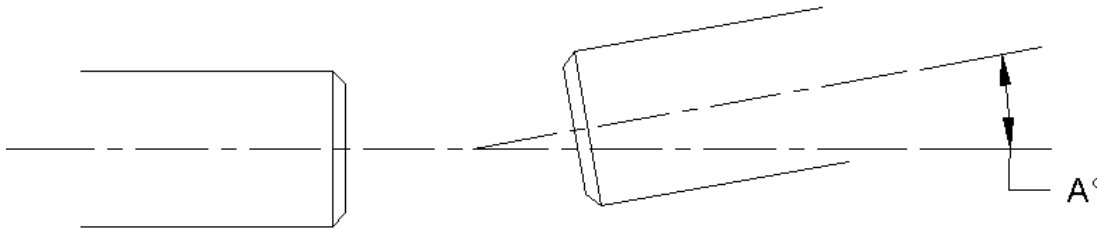

The angle of error, A° , between two shafts is the amount of angular misalignment.

Angular Misalignment

The condition which exists when the center lines of connected shafts are neither parallel nor co-axial. The amount of misalignment is the angle measured between the intersecting axes of the connected shafts.

Parallel Misalignment – (also known as radial or offset misalignment)

The lateral displacement between non-intersecting axis of the connected shafts.

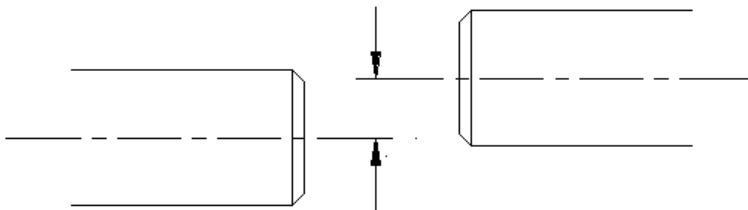

Axial Misalignment or End Float

The axial movement from the normal gap setting for a standard coupling. Frequently associated with thermal growth stated as a \pm value from the normal setting as specified by the coupling manufacturer.

Axial Stiffness

A measure of a couplings resistance to axial displacement.

Radial Stiffness

Radial stiffness is the measure of a coupling's resistance to parallel offset.

Angular Stiffness

A measure of a coupling's resistance to angular displacement.

Power Plane (coupling)

The power plane is the plane at the coupling interface where the torque is transmitted from one shaft to another.

Dial Indicator

A dial indicator is a gage with a calibrated circular face and is designed to measure distance variations.

Indicator Sag

Indicator sag is the difference in the indicator readings due to gravitational forces on the indicator and set up deflection from the top position (12:00 o'clock) and the bottom position (6:00 o'clock).

Soft Foot

Soft foot is a condition that occurs when there is not 100 % contact between the equipment mounting bracket or housing feet and, the mounting surface. Soft foot can be caused by an un-level surface, bent foot or improper shims. When the bolts are tightened, the joint under the equipment foot acts like a spring rather a rigid connection.

Pipe Strain

Pipe strain is the force exerted on a piece of equipment from a pipe, at the point of connection. Example would be a vertical pipe being supported by the flange of the pump. The weight of the pipe exerts its force on the housing of the pump.

Laser - A high intensity focused light beam.

Section 2 – Overview of Alignment**2.1 Importance of Alignment****Why Align equipment?**

The reason shaft alignment is critical is that it reduces the reactionary forces put upon the equipment by the deflection of the coupling. The greater the misalignment in the system, the greater the magnitude of the reactionary loads imparted by the coupling to the connected equipment. The level to which a system needs to be aligned is a direct function of the equipment's ability to handle the extra forces imposed on and by the coupling ability to accommodate misalignment. A gearbox bearing may have been selected to meet the loads produced by the gear mesh. If misalignment increases the bearing loads by 30%, the bearing may become overloaded and prematurely fail. To put those figures into real numbers: Based on standard AFBMA calculations, a 30% increase in load would result in a 58% reduction in bearing life. For the most part, the coupling misalignment rating should never be the basis for allowable system misalignment. System alignment should be based first on the minimum requirement of the driver and driven equipment, and then the coupling. Some couplings may have up to ten times the misalignment capability that the equipment will allow.

Better alignment produces lower reactionary loads. Lower reactionary loads result in, longer bearing, shaft, coupling and seal life, reduced vibration and reduced operating costs. The

ultimate goal of shaft alignment is to keep the equipment perfectly aligned in its operating condition. However, that may never be achievable and can be extremely costly and time consuming. So, to what level should a system be aligned? Once you have reached the misalignment goals of the equipment, any further reduction in misalignment helps reduce operating cost (e.g., bearing life). The level at which you give up trying to reach zero misalignment depends on the cost to benefit trade off and / or the time and equipment you have available to you

There are other outside factors that can also impart forces on the connected equipment and must be addressed to ensure proper functioning of the equipment. These forces must be eliminated prior to the system alignment. Some of the major sources of additional equipment loading are: pipe strain, foot plant (soft foot), equipment and coupling unbalance, and proper bore and key fit.

Pipe Strain

Pipe strain is the force that is put on a pump, for example, when the suction and discharge pipes are bolted up to it. If these pipes are not fitted up properly or, are not supported correctly, high forces will be transmitted to the pump housing. The forces may distort the bearing housings and adversely affect the bearing life. This condition may also make it impossible to maintain the equipment alignment.

Foot Plant (soft foot)

Foot plant is a condition for which all of the feet on a piece of equipment are not in contact with the base. Before the bolts are tightened, it may appear that you have the equipment aligned properly. However, when you tighten the bolts, undue strain is placed on the housing. As with pipe strain, forces may distort the housings and adversely affect the bearings or throw the equipment out of alignment. This condition can easily be fixed using shims.

Balance

Acceptable balance is needed for a smooth running train of equipment. If the speed of the equipment is low or the equipment is not sensitive to unbalance, additional coupling or equipment balance may not be needed. However, if the speeds are high or the system is very sensitive to an out of balance condition (close to critical speed) additional balancing may be required. The forces imparted to the equipment by an unbalance condition are proportional to the square of the speed. A doubling in speed can put 4 times the load on the equipment. The vibration can also cause bolts to loosen, housings to crack and can throw the equipment out of alignment.

2.2 Pre-Alignment Considerations

Before you can begin to align the equipment you must:

- 1) Eliminate pipe strain
- 2) Correct for any soft foot condition
- 3) Make sure the base under the equipment is solid and firmly attached to the structure.
- 4) Determine the thermal changes that may take place after the equipment is started up and running for a while.

Remember, it's the operating alignment that counts. For example, if one piece of equipment is next to a furnace all of the time and is connected to another piece of equipment through a long floating shaft type coupling, its center line may change when the furnace is turned on. The other equipment may not see the same change. Those thermal changes need to be taken into account. Sometimes this is very difficult to do.

- 5) Determine which piece of equipment should be moved.
Some equipment is just easier to make adjust. It is normally easier to move a motor than move a pump. You will not have all of the pipes to contend with. However, sometimes you may have to pick the harder piece of equipment because you can not turn the shaft on the easier one (used on runout check) or space constraints prevent a method of sliding one unit.
- 6) Determine the tools needed to do the job
 - a) Wrenches for all of the bolts
 - b) A device for lifting the unit to install or remove shims
 - c) A device for sliding the unit from one side to the other
- 7) Decide which alignment procedure to use. There are many, and each has its good and bad points.
- 8) Inspect the equipment for potential problems
 - a) Look for bent shafts
 - b) Look for cracked hubs
 - c) Make sure coupling hubs are firmly attached and have not spun on the shaft.
 - d) Check coupling bore to shaft clearances.
 - e) Look for any obstructions.

Section 3 – Types of Misalignment

3.1 Shaft – Angular Misalignment

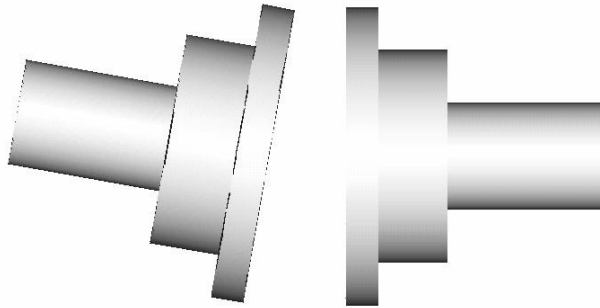

Shaft angular misalignment occurs when the shaft center lines of two pieces of equipment cross each other. The actual angle can be a compound angle in space. Breaking the compound angle into horizontal and vertical components and applying corrections individually solves the angular alignment problem.

Horizontal angular shaft misalignment is the misalignment as viewed when looking down on the equipment from above.

The vertical angular shaft misalignment is the misalignment as viewed from the side of the equipment

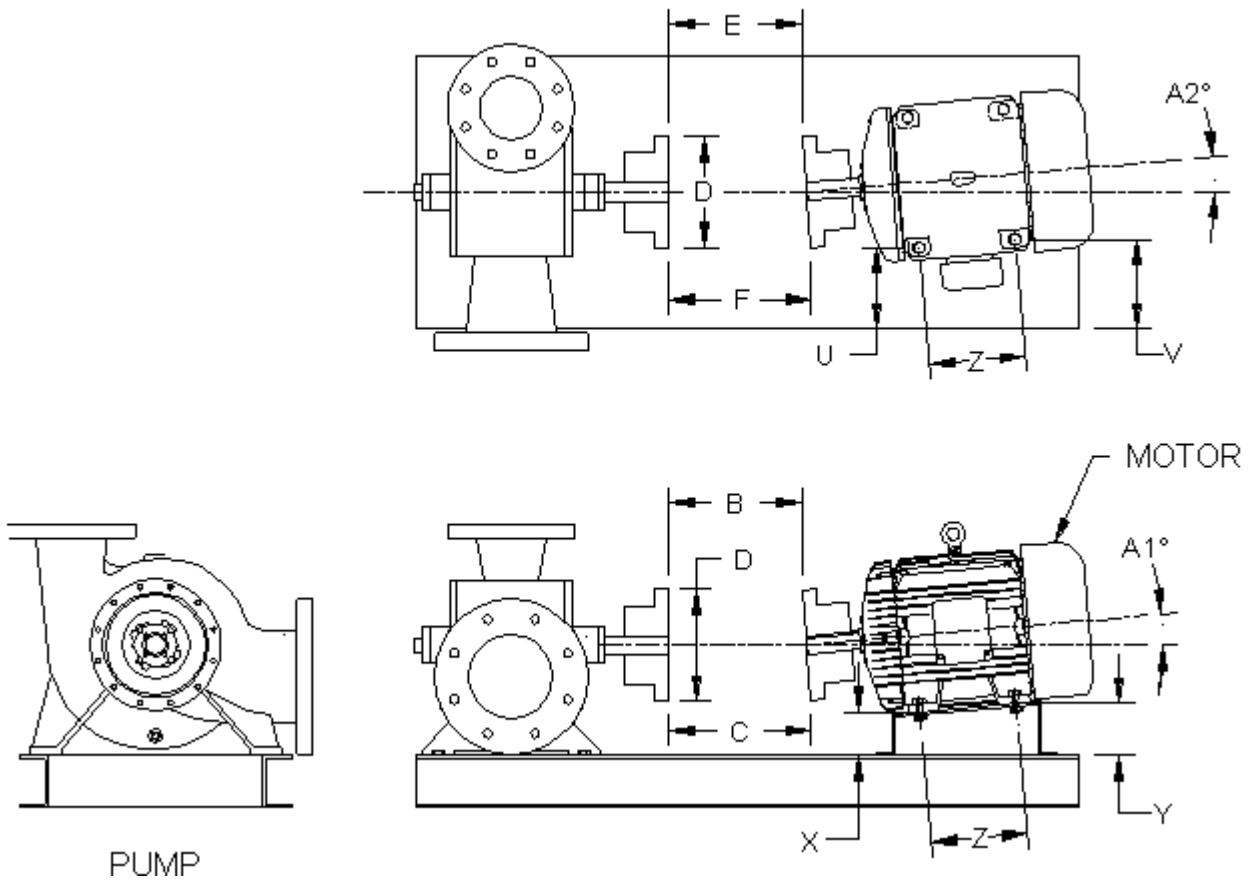

$A1^\circ = \text{Vertical Angular Misalignment Angle} = \text{Tan}^{-1} \left(\frac{C-B}{D} \right) \text{ (deg)}$

$$\frac{D}{Z} = \frac{C - B}{Y - X}$$

Change in Y or X to bring shafts into Vertical Angular Alignment

$$\Delta = \left(\frac{C - B}{D} \right) * Z$$

$A2^\circ = \text{Horizontal Angular Misalignment Angle} = \text{Tan}^{-1} \left(\frac{F-E}{D} \right) \text{ (deg)}$

$$\frac{D}{Z} = \frac{F - E}{Y - X}$$

Change in U or V to bring shafts into Vertical Angular Alignment

$$\Delta = \left(\frac{F - E}{D} \right) * Z$$

Figure 1

By measuring the distance between the flange faces of the coupling at the 12:00 and 6:00 positions, the vertical misalignment between the equipment shafts can be determined. Using the formulas listed above, one can calculate the required vertical adjustment of the mounting feet to make the shaft centers parallel in the vertical direction. See Figure 1. The same technique is used to correct for the horizontal angular misalignment.

Helpful Hint:

If you are learning how to perform alignment for the first time, it is suggested that you correct for angular misalignment first. When you have finished the angular corrections, you will be left with only parallel misalignment. This type of misalignment is discussed in the next section and is easier to compensate for once angular misalignment has been corrected.

3.2 Shaft –Parallel Misalignment

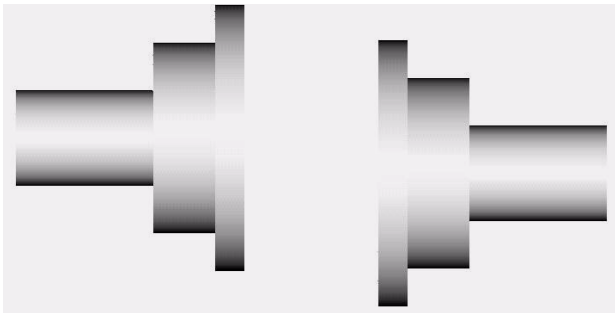

Shaft Parallel Offset misalignment is when two shaft center lines are parallel but not co-linear. Breaking the offset into a vertical and a horizontal component solves the alignment problem. Horizontal parallel offset is the shaft offset when looking down on the equipment from above. It is the side-to-side offset of the equipment. Vertical parallel offset is the shaft offset viewed from the side of the equipment. It is the up and down offset of the equipment.

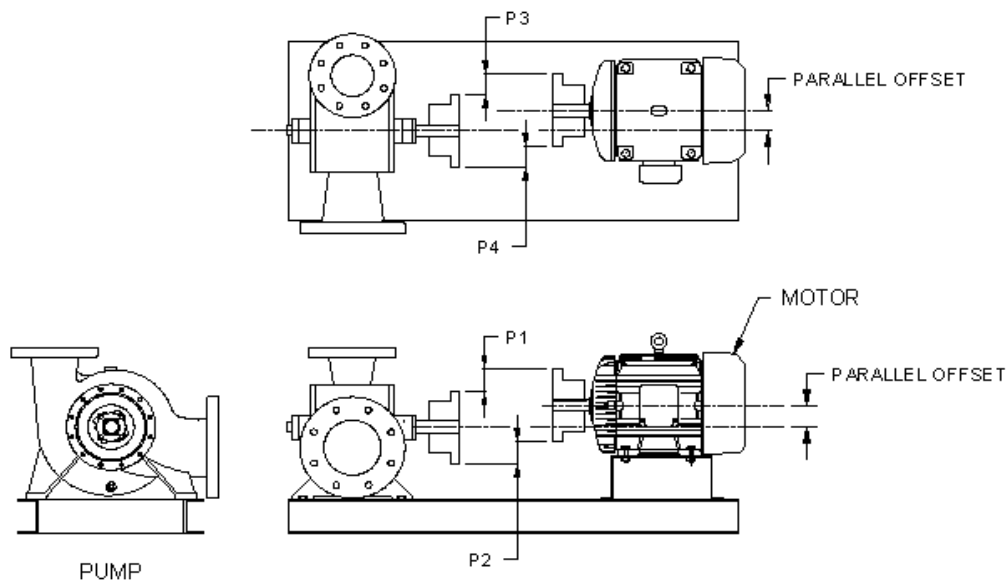

Figure 2

In both cases, the amount of parallel offset in the vertical or horizontal direction can be determined by measuring the distance from one point on the shaft or coupling hub to a corresponding point on the other shaft or hub (Distance P1 in Figure 2). The diagrams above show the measurement on the O.D. of the part. Any cylindrical surface can be used for the measurements. Repeat the measurements 180 deg away from the first point (Distance P2 in Figure 2). In the case of vertical shaft offset, check the distance between shafts or hubs at the 12:00 and 6:00 positions. The average of P1 and P2 is the vertical parallel offset. This is the amount the equipment needs to be moved up or down to make the shafts colinear in the vertical direction. Depending on the measurement method used, you may have to compensate the reading for indicator sag when checking vertical offset at the 6:00 position. (see Appendix A for instructions on calculating indicator sag. The horizontal offset would be measured at the 3:00 and 9:00 positions.

Whether a coupling can accommodate parallel offset misalignment, is a function of the number of flex planes, internal clearances between the coupling components and, the stiffness of the torque transmitting element. The greater the distance between the flex planes, the more parallel offset can be accommodated. Elastomeric couplings with just one flex plane are able to accommodate small amounts of parallel misalignment by deflection or distortion of the elastomeric element.

Section 4 - Comparison of Alignment Methods

Our discussion will show the methodology behind the most common methods of machinery alignment. The methods covered are the straight edge method, rim and face alignment, reverse indicator method, and laser alignment.

4.1) Straight Edge / Feeler Gage Method

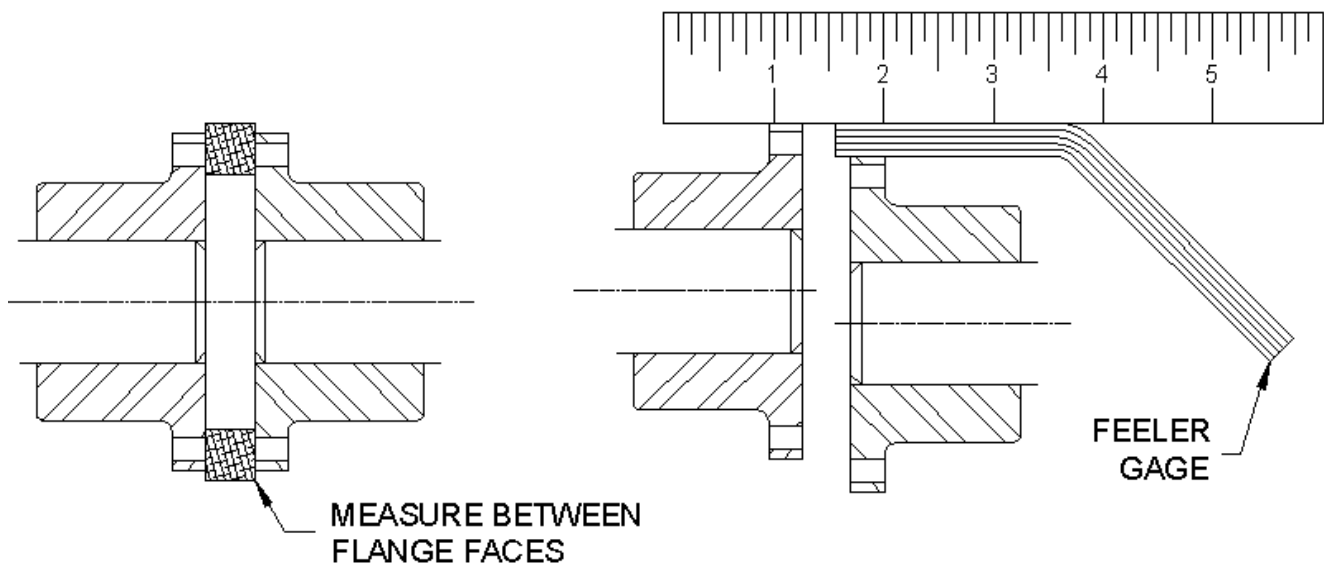

Figure 3

This method uses a feeler gage or calipers to measure the gap variation between the coupling hub faces to determine the shaft angular misalignment. Flange Gap measurements are taken and recorded at the 12:00, 3:00, 6:00 and 9:00 positions without rotating the shafts. Those values are then used to calculate the amount of vertical and horizontal angular misalignment. (see Shaft Angular Misalignment section 3.1). To measure vertical and horizontal parallel offset, a straight edge is placed across the hub flange outside diameter (see figure 3). A feeler gage is inserted between straight edge and the other hub O.D. Gap measurements are taken and recorded at the 12:00, 3:00, 6:00 and 9:00 positions. Those values are then used to calculate the amount of vertical and horizontal parallel misalignment. (see Shaft Parallel Misalignment section 3 B). The advantage of this method is that alignment can be completed quickly and no special tools are required. The disadvantage of this method is that it does not work if there is a large distance between hub faces. This type of alignment is accurate for some types of couplings but not others.

4.2) Rim / Face Method

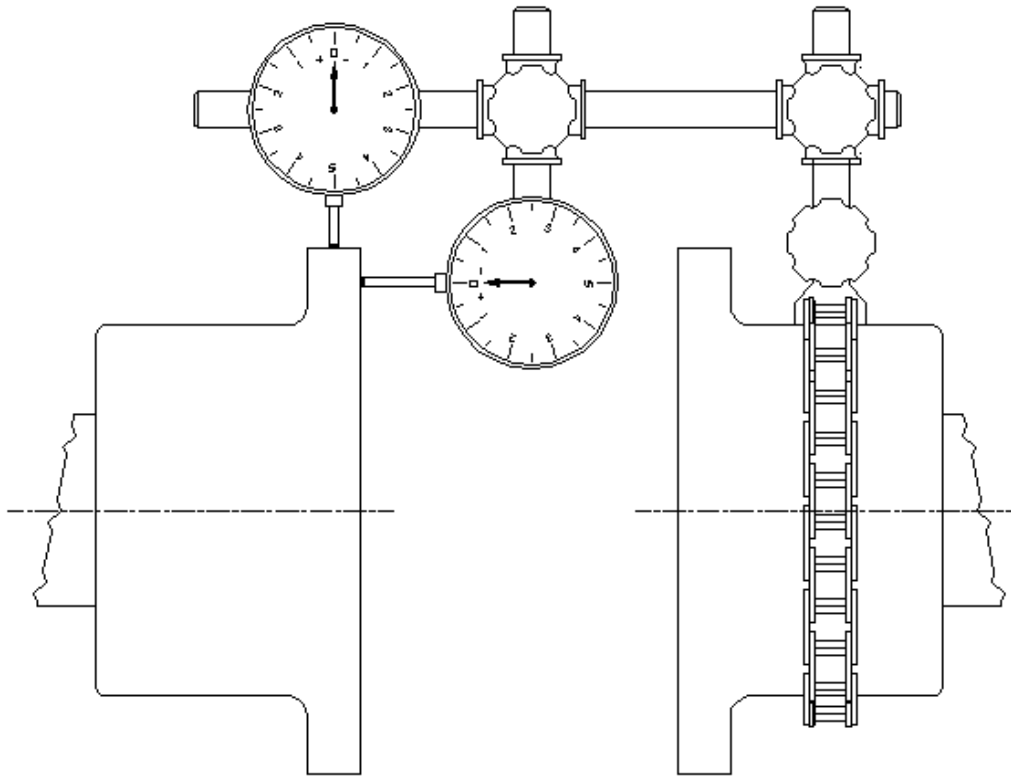

Figure 4

This method is very similar to the straight edge / feeler gage method except that two dial indicators are used to measure the gaps between the flanges and the O.D of the hubs. The dial indicators are mounted to a bar or beam that is rigidly affixed to one of the shafts or coupling hubs via a clamp. The dial indicators are slid down the beam and are set up to indicate off the OD (or any other cylindrical surface) and face of the other shaft or coupling hub. The indicators are set to zero at the 12:00 position (see Figure 4). Paint marks are placed on both hubs at the 12:00, 3:00, 6:00 and 9:00 positions and are used to help keep both shafts in the same orientation as the measurements are taken.. Instead of moving the gages to the next position, it is better to rotate both shafts together to take the reading at all 4 positions. This makes setup easier, more consistent and, by keeping the shafts in that same relative orientation, eliminates gage error that may occur if the faces or OD's have any runout. It is important to keep the equipment against the axial stops (thrust bearings) during this procedure to prevent inaccurate face readings. Because of gravitational forces, you must correct the reading at the 6:00 positions to compensate for indicator sag. (see Appendix A). Correction calculations are the same as with the feeler gage method. At some point, the span between two coupling faces may be so large that indicator sag is just too great to overcome.

4.3) Reverse Indicator Method

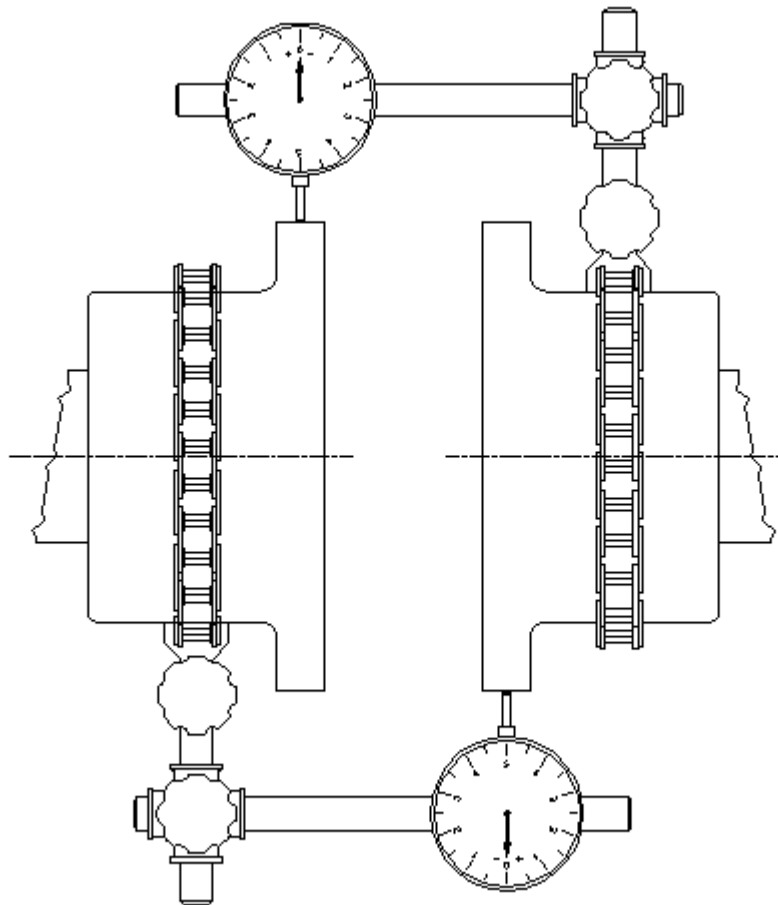

Figure 5

This method uses two dial indicators. One indicator is mounted on a beam attached to the left coupling hub or shaft and is set up to indicate on the right coupling hub or shaft. The other indicator is mounted on a beam attached to the right coupling hub or shaft and is set up to indicate on the left coupling hub. Paint marks are placed on both hubs at the 12:00, 3:00, 6:00 and 9:00 positions to help keep both shafts in the same relative orientation as the measurements are taken. The shafts are then rotated together and readings are taken at the 12:00, 3:00, 6:00 and 9:00 positions. The amount of correction to bring the two shafts into alignment is either mathematically calculated or is graphically plotted. Remember to account for indicator sag. See appendix A.

4.4) Laser Alignment

Laser Alignment methods use a laser beam emitter mounted to the hub or shaft of one piece of equipment and a receiver mounted on the other shaft or coupling hub. The emitter is electronically zeroed out at the 12:00 positions. The shafts are then rotated together to another position and new data readings are recorded and stored in the computer. A microprocessor then computes all of the necessary adjustment required to align the system. Laser Alignment methods offer the advantage that they are very fast and they significantly reduce the chance for errors. The drawback to Laser alignment systems is their equipment cost.

APPENDIX A

Determination of Indicator Sag

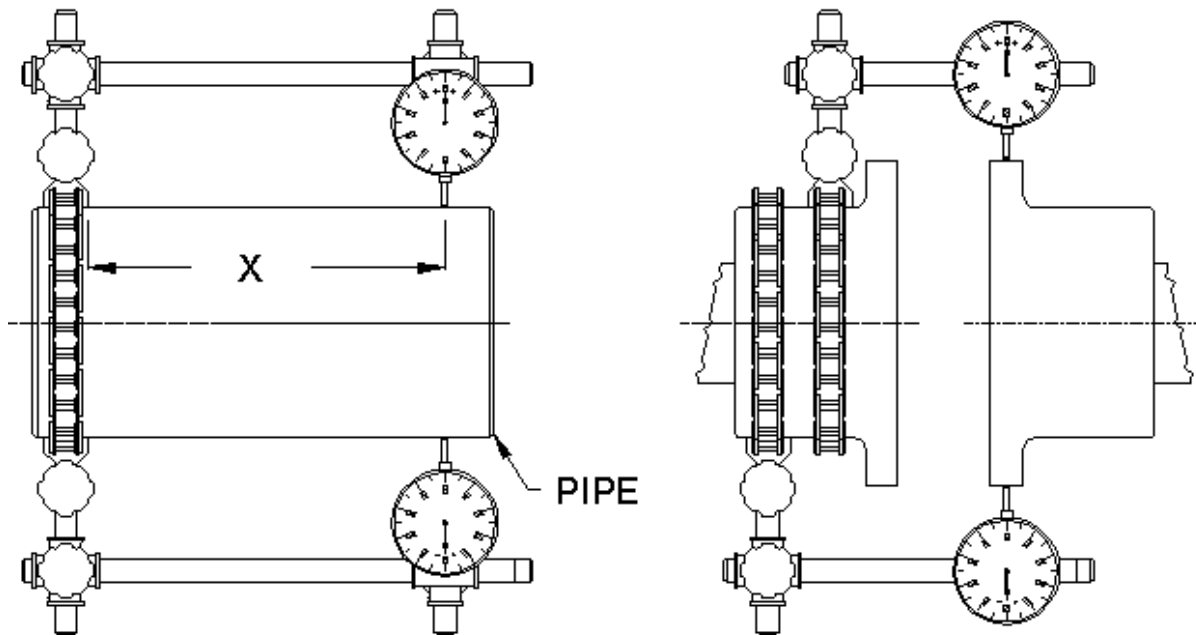

Figure 6

When dial bore gages are mounted on extension bars to measure distant objects, the weight of the gage can cause the mounting beam to bend. This bending causes the gage to give different readings depending on its orientation in space. To check the amount of sag, mount the gage onto a rigid pipe. Position the dial gage the same distance from the fixed end as will be measured on the equipment (dimension X on the diagram above). Set the dial gage to the zero at the 12:00 position. Rotate the pipe and gage assembly to the 6:00 position and read the gage. In the example shown above, the gage reads -0.01". This is the indicator sag for that position along the beam. If you move the gage closer or farther from the beams mounting point, the amount of sag will change and will have to be recalculated for the new distance.

If the gage set up is moved to the equipment, any reading taken at the 6:00 position would have to be corrected for the indicator sag that was calculated on the rigid pipe. For example, the indicator on the coupling hubs reads -0.03". We determined our indicator sag to be -.010. The actual measurement should be recorded as $-0.03 - (-0.01) = -0.02$ ".

Cautions on Runouts

Most of the techniques shown in this primer rely on the fact that both shafts can be rotated together. By taking the measurement at the same points on each part, the effects of runout are negated. No matter what method is used, runouts should always be checked and corrected if required before any alignment.